

power table EE 13 - EE 30

- * application as SMPS, open, impregnated or potted
- * application also as storage choke
- * custom-built development for switching frequencies from 20 kHz - 300 kHz (500 kHz) on your application, also for multiple output voltages
- * construction for safety electrical disconnection satisfying EN 61558-2-17 (VDE 0570 part 2-17) respectively EN 60950 respectively EN 60065 or IEC 601
- * optional: UL-insulating system class B for impregnated or potted transformer
- * ferrite components N 27, N 67, N 87 or N 97
- * also until t_a 105°C and class F (155°C) as special version possible
- * possible winding technique: copper wire and/or HF stranded wire in class F (155°C) copper foil winding, polyimide insulated wires (3-times bandage)

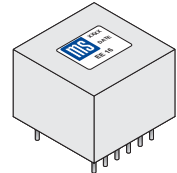
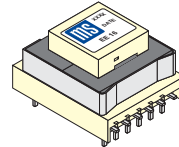
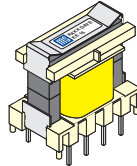
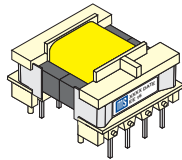

maximum power as flyback-, forward- or push-pull working type
guide number on practical experience and computer based model calculations
power table is for t_a 40°C / B, impregnated with N27 / N67 (standard)

type	frequency	flyback	forward	push-pull
EE 13	25 kHz	0,6 VA	0,8 VA	1,2 VA
	50 kHz	1,0 VA	1,2 VA	1,8 VA
	100 kHz	1,6 VA	2,0 VA	2,5 VA
EE 16	25 kHz	3,5 VA	4,0 VA	6,0 VA
	50 kHz	5,0 VA	6,0 VA	9,0 VA
	100 kHz	7,5 VA	9,0 VA	13,0 VA
EE 20	25 kHz	6,5 VA	8,0 VA	12,0 VA
	50 kHz	10,0 VA	12,0 VA	18,0 VA
	100 kHz	15,0 VA	18,0 VA	26,0 VA
EE 25	25 kHz	12,0 VA	15,0 VA	20,0 VA
	50 kHz	18,0 VA	22,0 VA	34,0 VA
	100 kHz	26,0 VA	32,0 VA	45,0 VA
EE 30	25 kHz	25,0 VA	30,0 VA	40,0 VA
	50 kHz	40,0 VA	45,0 VA	60,0 VA
	100 kHz	55,0 VA	65,0 VA	90,0 VA

power table EE 42 - EE 65

- * application as SMPS, open, impregnated or potted
- * application also as storage choke
- * custom-built development for switching frequencies from 20 kHz - 300 kHz (500 kHz) on your application, also for multiple output voltages
- * construction for safety electrical disconnection satisfying EN 61558-2-17 (VDE 0570 part 2-17) respectively EN 60950 respectively EN 60065 or IEC 601
- * optional: UL-insulating system class B for impregnated or potted transformer
- * ferrite components N 27, N 67, N 87 or N 97
- * also until t_a 105°C and class F (155°C) as special version possible
- * possible winding technique: copper wire and/or HF stranded wire in class F (155°C) copper foil winding, polyimide insulated wires (3-times bandage)



maximum power as flyback-, forward- or push-pull working type
guide number on practical experience and computer based model calculations
power table is for t_a 40°C / B, impregnated with N27 / N67 (standard)

type	frequency	flyback	forward	push-pull
EE 42/15 impregnated	25 kHz	75 VA	95 VA	185 VA
	50 kHz	150 VA	180 VA	280 VA
	100 kHz	240 VA	280 VA	440 VA
EE 42/15 potted	25 kHz	80 VA	105 VA	200 VA
	50 kHz	165 VA	200 VA	300 VA
	100 kHz	265 VA	310 VA	490 VA
EE 42/20 impregnated	25 kHz	100 VA	125 VA	250 VA
	50 kHz	200 VA	240 VA	420 VA
	100 kHz	325 VA	375 VA	600 VA
EE 42/20 potted	25 kHz	110 VA	140 VA	275 VA
	50 kHz	220 VA	270 VA	460 VA
	100 kHz	350 VA	400 VA	650 VA
EE 55/21 impregnated	25 kHz	180 VA	230 VA	460 VA
	50 kHz	360 VA	440 VA	770 VA
	100 kHz	-	680 VA	1000 VA
EE 55/21 potted	25 kHz	200 VA	250 VA	500 VA
	50 kHz	400 VA	480 VA	850 VA
	100 kHz	-	750 VA	1100 VA
EE 55/25 impregnated	25 kHz	240 VA	310 VA	625 VA
	50 kHz	-	600 VA	1000 VA
	100 kHz	-	920 VA	1350 VA
EE 55/25 potted	25 kHz	260 VA	340 VA	680 VA
	50 kHz	-	650 VA	1100 VA
	100 kHz	-	1000 VA	1500 VA
EE 65 impregnated	25 kHz	340 VA	400 VA	800 VA
	50 kHz	400 VA	760 VA	1250 VA
	100 kHz	-	1150 VA	1750 VA
EE 65 potted	25 kHz	370 VA	440 VA	880 VA
	50 kHz	-	825 VA	1350 VA
	100 kHz	-	1250 VA	1950 VA

type EE 8,8 SMD

0,6 ... 1,3 VA

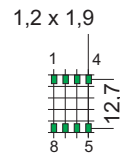
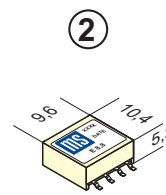
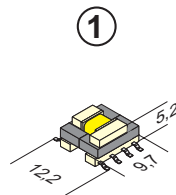

view on pin side
pin grid = 5,08 mm

EE 8,8	maximum power as flyback-, forward- or push-pull working type guide number on practical experience and computer based model calculations power table is for ta 40°C / B, impregnated with N27 / N67 (standard)			
	frequency	flyback	forward	push-pull
	100 kHz	0,6 VA	0,9 VA	1,3 VA

- * application as DC/DC-transducer, open, impregnated or potted
- * application also as storage choke
- * custom-built development for switching frequencies from 20 kHz - 500 kHz on your application, also for multiple output voltages
- * optional: UL-insulating system class B for impregnated or potted transformer
- * ferrite components N 87
- * also until ta 105°C and class F (155°C) as special version possible
- * possible winding technique: copper wire and/or HF stranded wire in class F (155°C) copper foil winding, polyimid insulated wires (3-times bandage)

type EE 13

0,6 ... 2,5 VA

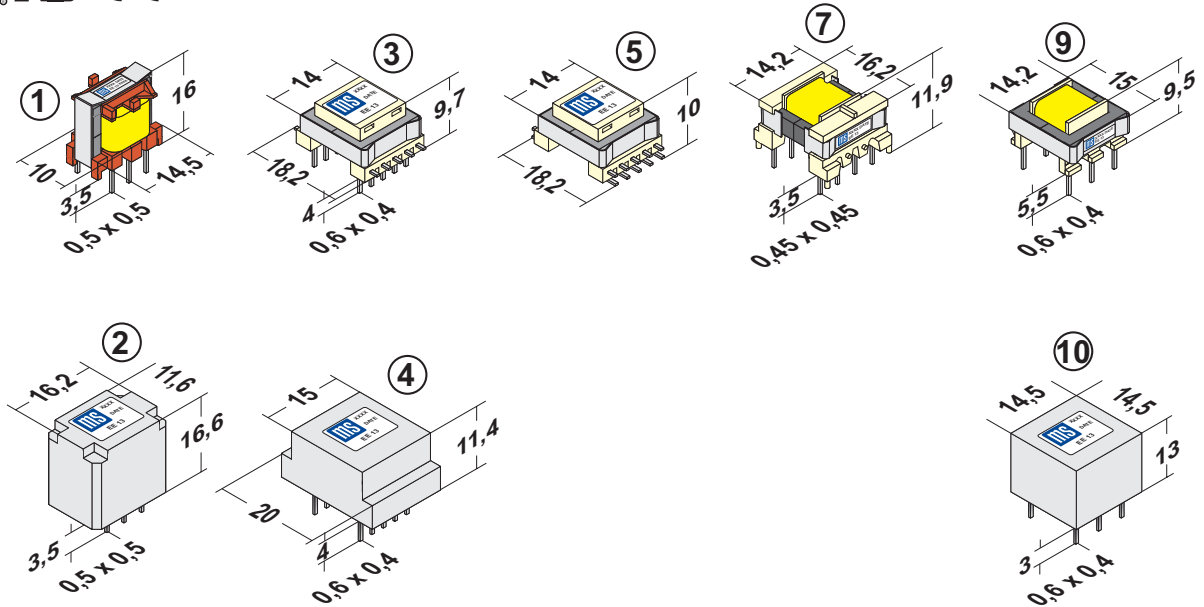

*) in preparation

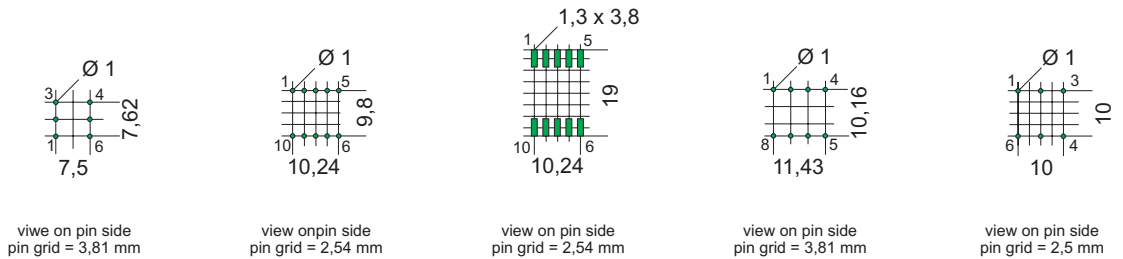

EE 13	maximum power as flyback-, forward- or push-pull working type guide number on practical experience and computer based model calculations power table is for ta 40°C / B, impregnated with N27 / N67 (standard)			
	frequency	flyback	forward	push-pull
	25 kHz	0,6 VA	0,8 VA	1,2 VA
	50 kHz	1,0 VA	1,2 VA	1,8 VA
100 kHz	1,6 VA	2,0 VA	2,5 VA	

- * application as SMPS, open, impregnated or potted
- * application also as storage choke
- * custom-built development for switching frequencies from 20 kHz - 300 kHz (500 kHz) on your application, also for multiple output voltages
- * construction for safety electrical disconnection satisfying EN 61558-2-17 (VDE 0570 part 2-17) respectively EN 60950 respectively EN 60065 or IEC 601
- * optional: UL-insulating system class B for impregnated or potted transformer
- * ferrite components N 27, N 67, N 87 or N 97
- * also until ta 105°C and class F (155°C) as special version possible
- * possible winding technique: copper wire and/or HF stranded wire in class F (155°C) copper foil winding, polyimid insulated wires (3-times bandage)

9810

technical changes reserved

type EE 16

3,5 ... 13 VA

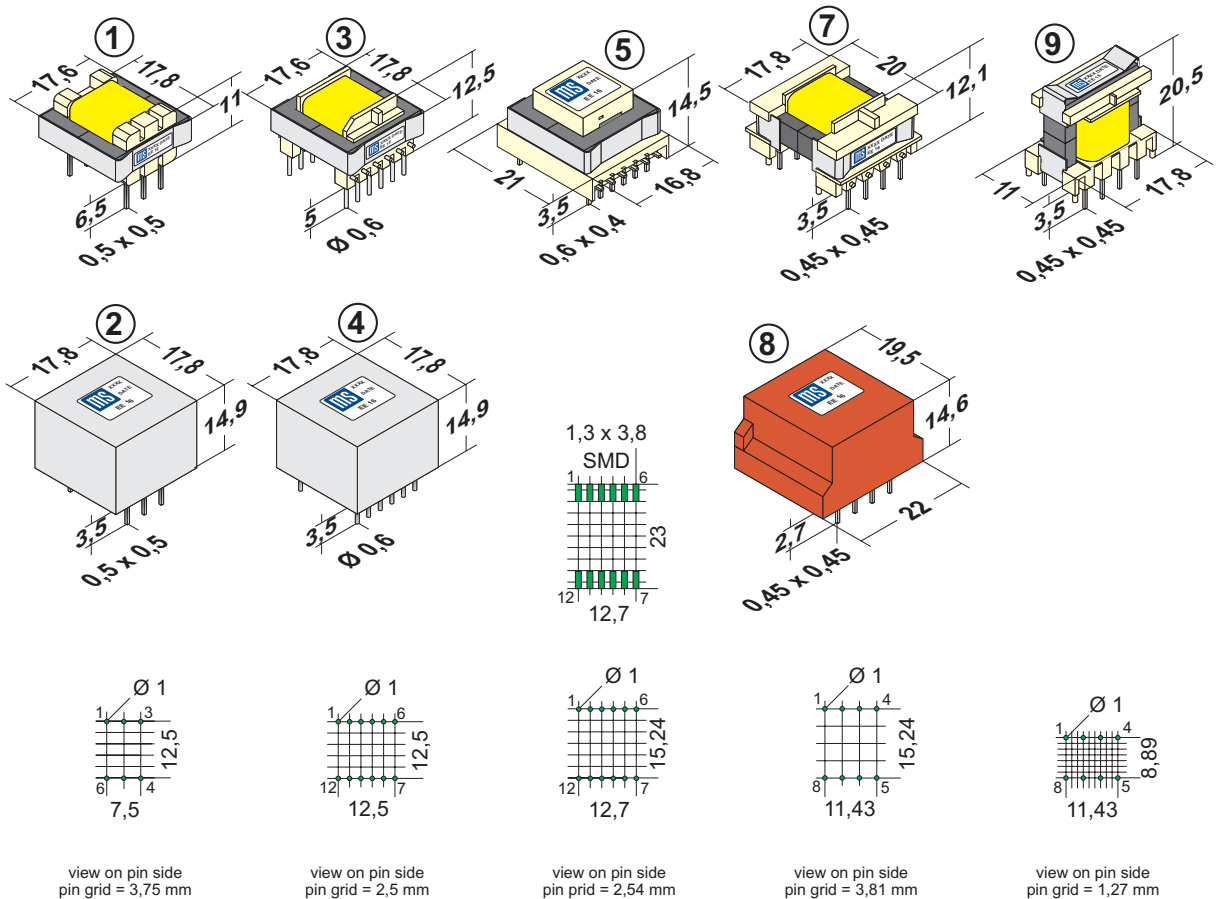

EE 16	maximum power as flyback-, forward- or push-pull working type guide number on practical experience and computer based model calculations power table is for ta 40°C / B, impregnated with N27 / N67 (standard)			
	frequency	flyback	forward	push-pull
	25 kHz	3,5 VA	4,0 VA	6,0 VA
	50 kHz	5,0 VA	6,0 VA	9,0 VA
100 kHz	7,5 VA	9,0 VA	13,0 VA	

- * application as SMPS, open, impregnated or potted
- * application also as storage choke
- * custom-built development for switching frequencies from 20 kHz - 300 kHz (500 kHz) on your application, also for multiple output voltages
- * construction for safety electrical disconnection satisfying EN 61558-2-17 (VDE 0570 part 2-17) respectively EN 60950 respectively EN 60065 or IEC 601
- * optional: UL-insulating system class B for impregnated or potted transformer
- * ferrite components N 27, N 67, N 87 or N 97
- * also until ta 105°C and class F (155°C) as special version possible
- * possible winding technique: copper wire and/or HF stranded wire in class F (155°C) copper foil winding, polyimid insulated wires (3-times bandage)

type EE 20

6,5 ... 26 VA

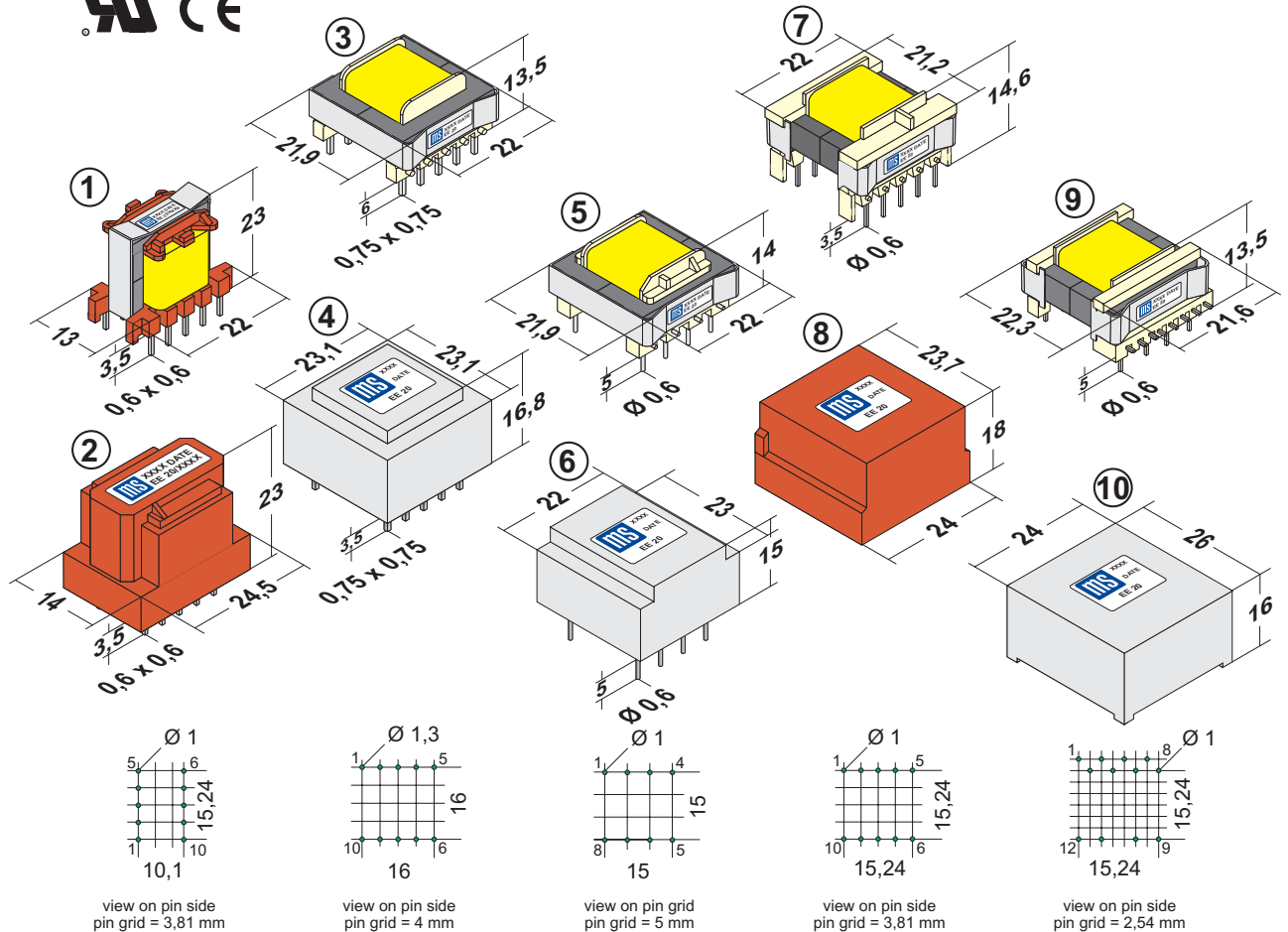

EE 20

maximum power as flyback-, forward- or push-pull working type
guide number on practical experience and computer based model calculations
power table is for ta 40°C / B, impregnated with N27 / N67 (standard)

frequency	flyback	forward	push-pull
25 kHz	6,5 VA	8,0 VA	12,0 VA
50 kHz	10,0 VA	12,0 VA	18,0 VA
100 kHz	15,0 VA	18,0 VA	26,0 VA

- * application as SMPS, open, impregnated or potted
- * application also as storage choke
- * custom-built development for switching frequencies from 20 kHz - 300 kHz (500 kHz) on your application, also for multiple output voltages
- * construction for safety electrical disconnection satisfying EN 61558-2-17 (VDE 0570 part 2-17) respectively EN 60950 respectively EN 60065 or IEC 601
- * optional: UL-insulating system class B for impregnated or potted transformer
- * ferrite components N 27, N 67, N 87 or N 97
- * also until ta 105°C and class F (155°C) as special version possible
- * possible winding technique: copper wire and/or HF stranded wire in class F (155°C) copper foil winding, polyimid insulated wires (3-times bandage)

type EE 20

6,5 ... 26 VA

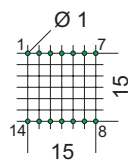
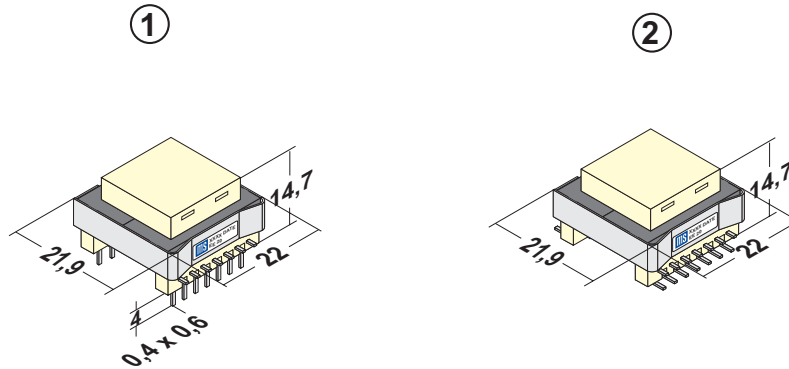

view on pin side
pin grid = 2,5 mm

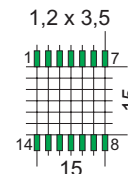

view on pin side
pin grid = 2,5 mm

EE 20

maximum power as flyback-, forward- or push-pull working type
guide number on practical experience and computer based model calculations
power table is for t_a 40°C / B, impregnated with N27 / N67 (standard)

frequency	flyback	forward	push-pull
25 kHz	6,5 VA	8,0 VA	12,0 VA
50 kHz	10,0 VA	12,0 VA	18,0 VA
100 kHz	15,0 VA	18,0 VA	26,0 VA

- * application as SMPS, open, impregnated or potted
- * application also as storage choke
- * custom-built development for switching frequencies from 20 kHz - 300 kHz (500 kHz) on your application, also for multiple output voltages
- * construction for safety electrical disconnection satisfying EN 61558-2-17 (VDE 0570 part 2-17) respectively EN 60950 respectively EN 60065 or IEC 601
- * optional: UL-insulating system class B for impregnated transformer
- * ferrite components N 27, N 67, N 87 or N 97
- * also until t_a 105°C and class F (155°C) as special version possible
- * possible winding technique: copper wire and/or HF stranded wire in class F (155°C) copper foil winding, polyimid insulated wires (3-times bandage)

type EE 25

12 ... 45 VA

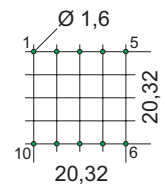
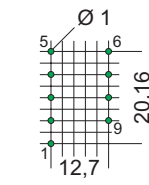
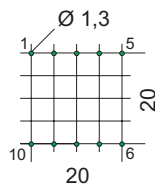
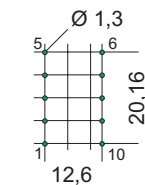
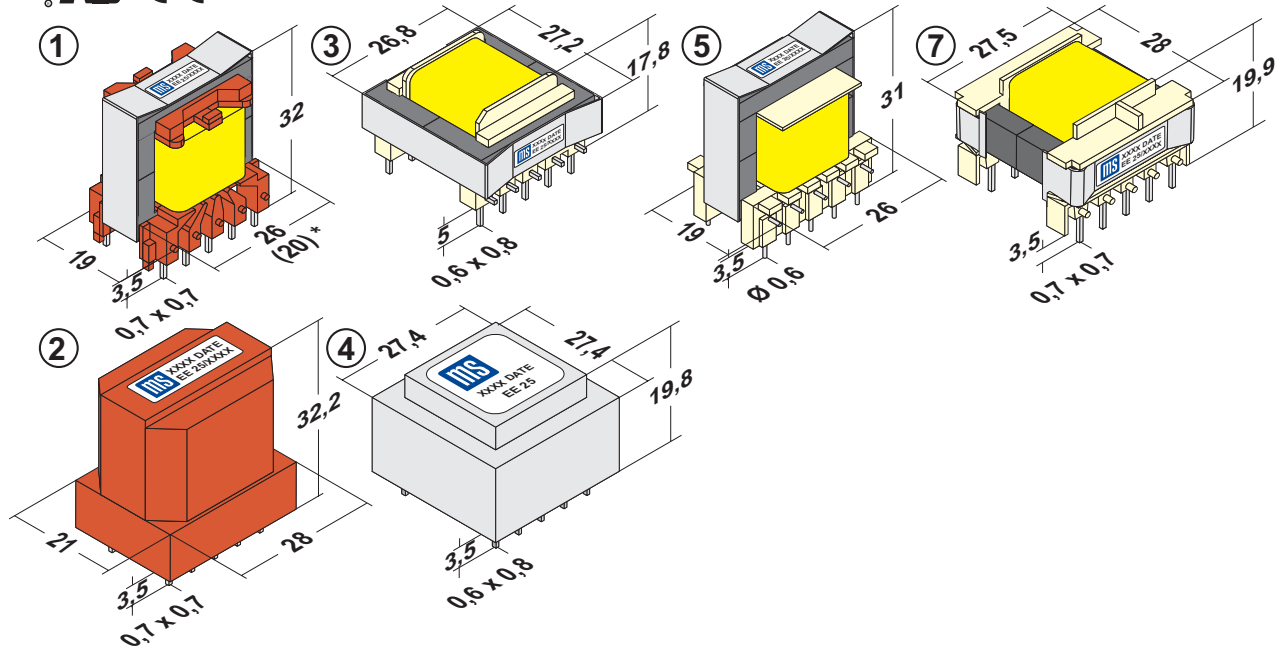

EE 25	maximum power as flyback-, forward- or push-pull working type guide number on practical experience and computer based model calculations power table is for ta 40°C / B, impregnated with N27 / N67 (standard)			
	frequency	flyback	forward	push-pull
	25 kHz	12 VA	15 VA	20 VA
	50 kHz	18 VA	22 VA	34 VA
	100 kHz	26 VA	32 VA	45 VA

- * application as SMPS, open, impregnated or potted
- * application also as storage choke
- * custom-built development for switching frequencies from 20 kHz - 300 kHz (500 kHz) on your application, also for multiple output voltages
- * construction for safety electrical disconnection satisfying EN 61558-2-17 (VDE 0570 part 2-17) respectively EN 60950 respectively EN 60065 or IEC 601
- * optional: UL-insulating system class B for impregnated or potted transformer
- * ferrite components N 27, N 67, N 87 or N 97
- * also until ta 105°C and class F (155°C) as special version possible
- * possible winding technique: copper wire and/or HF stranded wire in class F (155°C) copper foil winding, polyimid insulated wires (3-times bandage)

type EE 30 potted

25 ... 90 VA

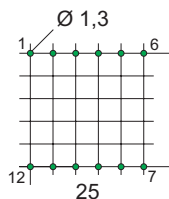
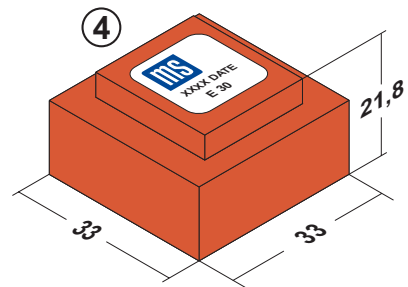
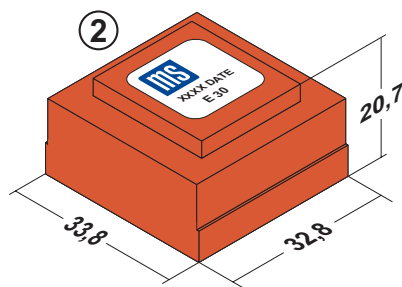
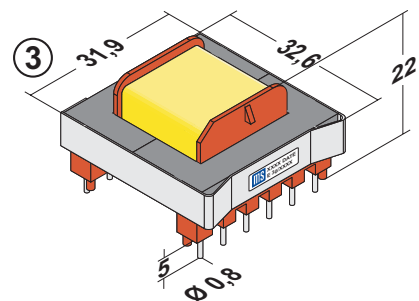
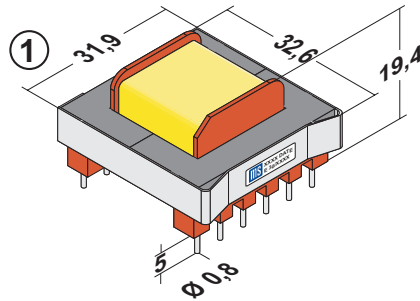

view on pin side
pin grid = 5 mm

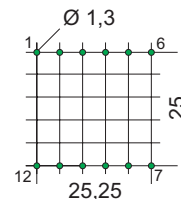

view on pin side
pin grid = 5,05 mm

EE 30

maximum power as flyback-, forward- or push-pull working type
guide number on practical experience and computer based model calculations
power table is for ta 40°C / B, impregnated with N27 / N67 (standard)

frequency	flyback	forward	push-pull
25 kHz	25 VA	30 VA	40 VA
50 kHz	40 VA	45 VA	60 VA
100 kHz	55 VA	65 VA	90 VA

- * application as SMPS, open, impregnated or potted
- * application also as storage choke
- * custom-built development for switching frequencies from 20 kHz - 300 kHz (500 kHz) on your application, also for multiple output voltages
- * construction for safety electrical disconnection satisfying EN 61558-2-17 (VDE 0570 part 2-17) respectively EN 60950 respectively EN 60065 or IEC 601
- * optional: UL-insulating system class B for impregnated or potted transformer
- * ferrite components N 27, N 67, N 87 or N 97
- * also until ta 105°C and class F (155°C) as special version possible
- * possible winding technique: copper wire and/or HF stranded wire in class F (155°C) copper foil winding, polyimid insulated wires (3-times bandage)

type EE 30 impregnated

25 ... 90 VA

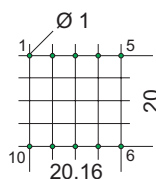
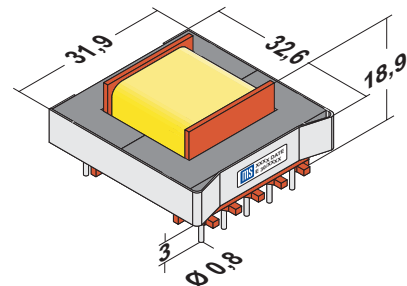
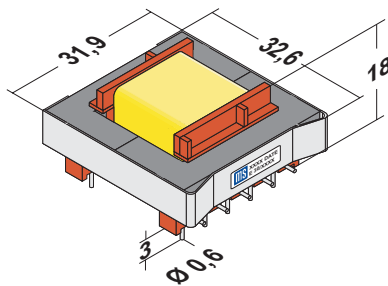

view on pin side
pin grid = 5,04 mm

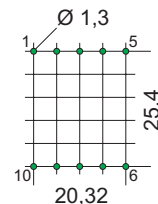

view on pin side
pin grid = 5,08 mm

EE 30

maximum power as flyback-, forward- or push-pull working type
guide number on practical experience and computer based model calculations
power table is for ta 40°C / B, impregnated with N27 / N67 (standard)

frequency	flyback	forward	push-pull
25 kHz	25 VA	30 VA	40 VA
50 kHz	40 VA	45 VA	60 VA
100 kHz	55 VA	65 VA	90 VA

- * application as SMPS, open or impregnated
- * application also as storage choke
- * custom-built development for switching frequencies from 20 kHz - 300 kHz (500 kHz) on your application, also for multiple output voltages
- * construction for safety electrical disconnection satisfying EN 61558-2-17 (VDE 0570 part 2-17) respectively EN 60950 respectively EN 60065 or IEC 601
- * optional: UL-insulating system class B for impregnated transformer
- * ferrite components N 27, N 67, N 87 or N 97
- * also until ta 105°C and class F (155°C) as special version possible
- * possible winding technique: copper wire and/or HF stranded wire in class F (155°C) copper foil winding, polyimid insulated wires (3-times bandage)

type EE 32/11 standing, impregnated 50 ... 240 VA

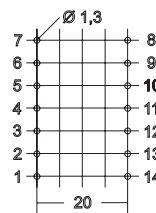
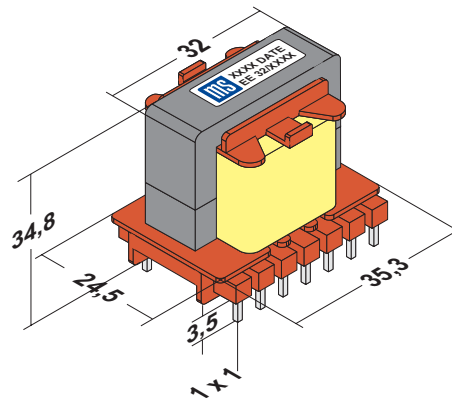

view on pin side
pin grid = 5 mm

EE 32	maximum power as flyback-, forward- or push-pull working type guide number on practical experience and computer based model calculations power table is for ta 40°C / B, impregnated with N27 / N67 (standard)			
	frequency	flyback	forward	push-pull
	25 kHz	50 VA	60 VA	110 VA
	50 kHz	90 VA	100 VA	160 VA
	100 kHz	120 VA	160 VA	240 VA

- * application as SMPS, open or impregnated
- * application also as storage choke
- * custom-built development for switching frequencies from 20 kHz - 300 kHz (500 kHz) on your application, also for multiple output voltages
- * construction for safety electrical disconnection satisfying EN 61558-2-17 (VDE 0570 part 2-17) respectively EN 60950 respectively EN 60065 or IEC 601
- * optional: UL-insulating system class B for impregnated transformer
- * ferrite components N 27, N 67, N 87 or N 97
- * also until ta 105°C and class F (155°C) as special version possible
- * possible winding technique: copper wire and/or HF stranded wire in class F (155°C) copper foil winding, polyimid insulated wires (3-times bandage)

type EE 32/11 potted

55 ... 260 VA

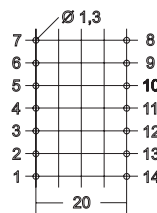
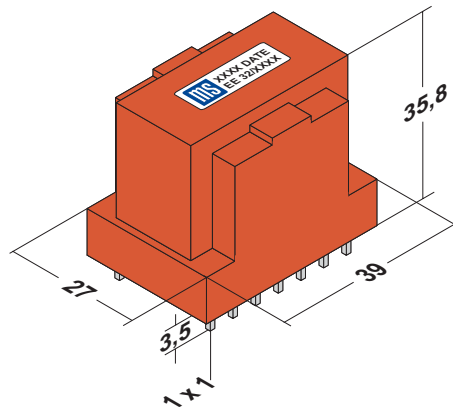

view on pin side
pin grid = 5 mm

EE 32

maximum power as flyback-, forward- or push-pull working type
guide number on practical experience and computer based model calculations
power table is for t_a 40°C / B, impregnated with N27 / N67 (standard)

frequency	flyback	forward	push-pull
25 kHz	55 VA	65 VA	120 VA
50 kHz	95 VA	110 VA	175 VA
100 kHz	130 VA	175 VA	260 VA

- * application as SMPS, potted
- * application also as storage choke
- * custom-built development for switching frequencies from 20 kHz - 300 kHz (500 kHz) on your application, also for multiple output voltages
- * construction for safety electrical disconnection satisfying EN 61558-2-17 (VDE 0570 part 2-17) respectively EN 60950 respectively EN 60065 or IEC 601
- * optional: UL-insulating system class B for potted transformer
- * ferrite components N 27, N 67, N 87 or N 97
- * also until t_a 105°C and class F (155°C) as special version possible
- * possible winding technique: copper wire and/or HF stranded wire in class F (155°C) copper foil winding, polyimid insulated wires (3-times bandage)

type EE 42/15 impregnated

75 ... 440 VA

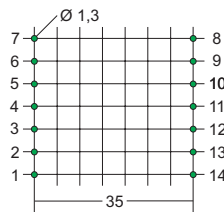
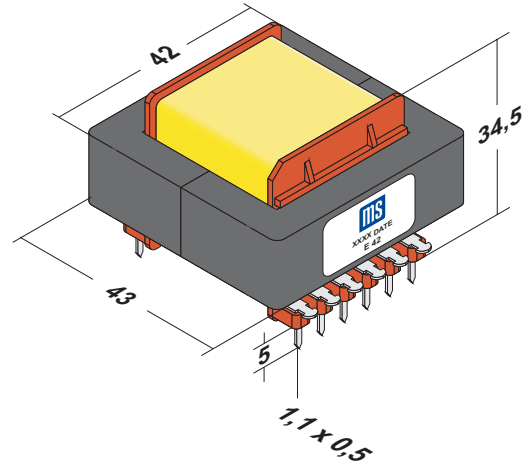
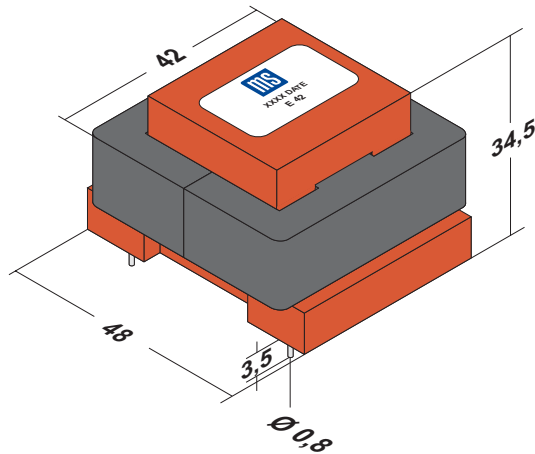

view on pin side
pin grid = 5 mm

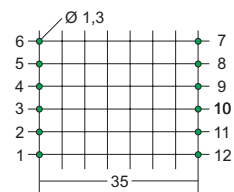

view on pin side
pin grid = 5 mm

EE 42

**maximum power as flyback-, forward- or push-pull working type
guide number on practical experience and computer based model calculations
power table is for ta 40°C / B, impregnated with N27 / N67 (standard)**

frequency	flyback	forward	push-pull
25 kHz	75 VA	95 VA	185 VA
50 kHz	150 VA	180 VA	280 VA
100 kHz	240 VA	280 VA	440 VA

- * application as SMPS, open or impregnated
- * application also as storage choke
- * custom-built development for switching frequencies from 20 kHz - 300 kHz (500 kHz) on your application, also for multiple output voltages
- * construction for safety electrical disconnection satisfying EN 61558-2-17 (VDE 0570 part 2-17) respectively EN 60950 respectively EN 60065 or IEC 601
- * optional: UL-insulating system class B for impregnated transformer
- * ferrite components N 27, N 67, N 87 or N 97
- * also until ta 105°C and class F (155°C) as special version possible
- * possible winding technique: copper wire and/or HF stranded wire in class F (155°C) copper foil winding, polyimid insulated wires (3-times bandage)

type EE 42/15 standing impregnated

75 ... 440 VA

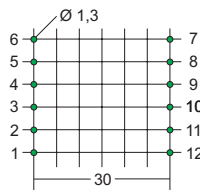
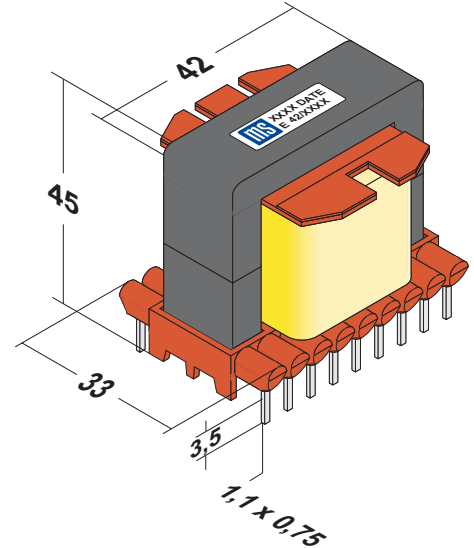
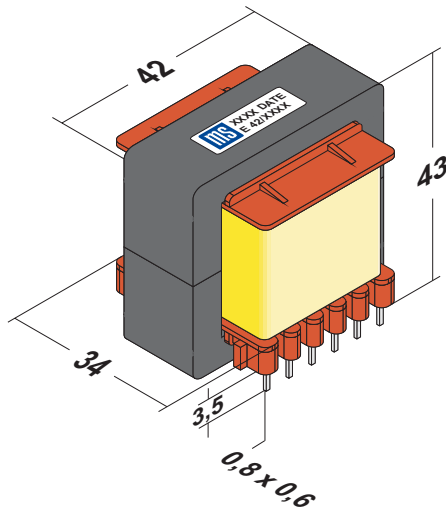

view on pin side
pin grid = 5 mm

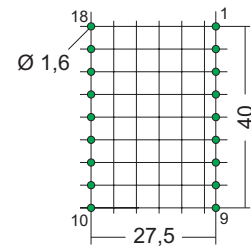

view on pin side
pin grid = 5 mm

EE 42

**maximum power as flyback-, forward- or push-pull working type
guide number on practical experience and computer based model calculations
power table is for ta 40°C / B, impregnated with N27 / N67 (standard)**

frequency	flyback	forward	push-pull
25 kHz	75 VA	95 VA	185 VA
50 kHz	150 VA	180 VA	280 VA
100 kHz	240 VA	280 VA	440 VA

- * application as SMPS, open or impregnated
- * application also as storage choke
- * custom-built development for switching frequencies from 20 kHz - 300 kHz (500 kHz) on your application, also for multiple output voltages
- * construction for safety electrical disconnection satisfying EN 61558-2-17 (VDE 0570 part 2-17) respectively EN 60950 respectively EN 60065 or IEC 601
- * optional: UL-insulating system class B for impregnated transformer
- * ferrite components N 27, N 67, N 87 or N 97
- * also until ta 105°C and class F (155°C) as special version possible
- * possible winding technique: copper wire and/or HF stranded wire in class F (155°C) copper foil winding, polyimid insulated wires (3-times bandage)

type EE 42/15 potted

80 ... 490 VA

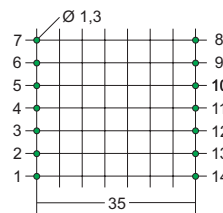
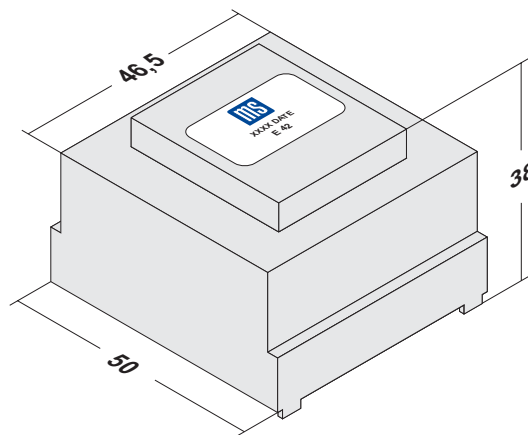

view on pin side
pin grid = 5 mm

EE 42	maximum power as flyback-, forward- or push-pull working type guide number on practical experience and computer based model calculations power table is for ta 40°C / B, impregnated with N27 / N67 (standard)			
	frequency	flyback	forward	push-pull
	25 kHz	80 VA	105 VA	200 VA
	50 kHz	165 VA	200 VA	300 VA
	100 kHz	265 VA	310 VA	490 VA

- * application as SMPS, potted
- * application also as storage choke
- * custom-built development for switching frequencies from 20 kHz - 300 kHz (500 kHz) on your application, also for multiple output voltages
- * construction for safety electrical disconnection satisfying EN 61558-2-17 (VDE 0570 part 2-17) respectively EN 60950 respectively EN 60065 or IEC 601
- * optional: UL-insulating system class B for potted transformer
- * ferrite components N 27, N 67, N 87 or N 97
- * also until ta 105°C and class F (155°C) as special version possible
- * possible winding technique: copper wire and/or HF stranded wire in class F (155°C) copper foil winding, polyimid insulated wires (3-times bandage)

type EE 42/20 impregnated

100 ... 600 VA

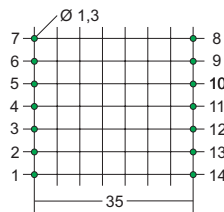
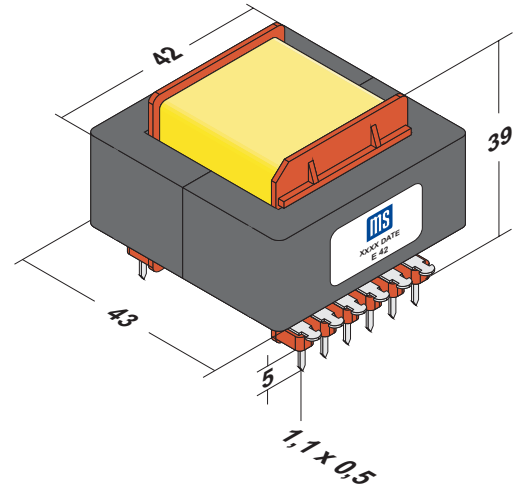
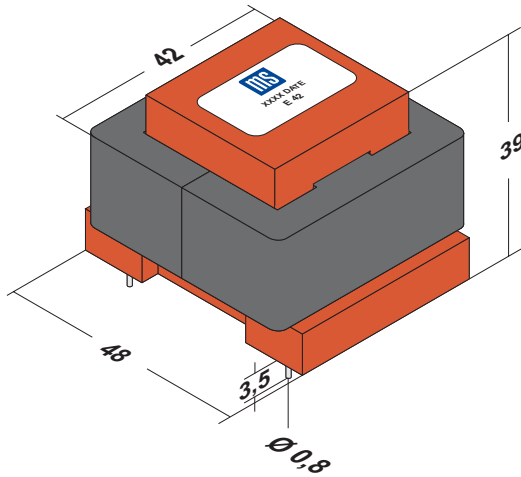

view on pin side
pin grid = 5 mm

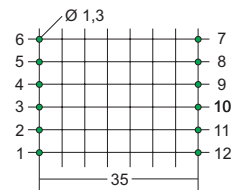

view on pin side
pin grid = 5 mm

EE 42

**maximum power as flyback-, forward- or push-pull working type
guide number on practical experience and computer based model calculations
power table is for ta 40°C / B, impregnated with N27 / N67 (standard)**

frequency	flyback	forward	push-pull
25 kHz	100 VA	125 VA	250 VA
50 kHz	200 VA	240 VA	420 VA
100 kHz	325 VA	375 VA	600 VA

- * application as SMPS, open or impregnated
- * application also as storage choke
- * custom-built development for switching frequencies from 20 kHz - 300 kHz (500 kHz) on your application, also for multiple output voltages
- * construction for safety electrical disconnection satisfying EN 61558-2-17 (VDE 0570 part 2-17) respectively EN 60950 respectively EN 60065 or IEC 601
- * optional: UL-insulating system class B for impregnated transformer
- * ferrite components N 27, N 67, N 87 or N 97
- * also until ta 105°C and class F (155°C) as special version possible
- * possible winding technique: copper wire and/or HF stranded wire in class F (155°C) copper foil winding, polyimid insulated wires (3-times bandage)

type EE 42/20 standing impregnated 100 ... 600 VA

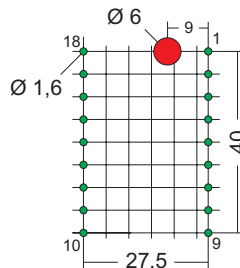
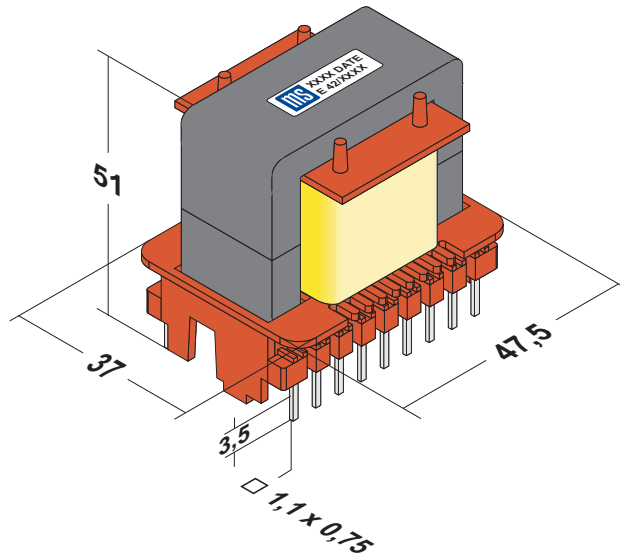

view on pin side
pin grid = 5 mm

EE 42	maximum power as flyback-, forward- or push-pull working type guide number on practical experience and computer based model calculations power table is for ta 40°C / B, impregnated with N27 / N67 (standard)			
	frequency	flyback	forward	push-pull
	25 kHz	100 VA	125 VA	250 VA
	50 kHz	200 VA	240 VA	420 VA
100 kHz	325 VA	375 VA	600 VA	

- * application as SMPS, open or impregnated
- * application also as storage choke
- * custom-built development for switching frequencies from 20 kHz - 300 kHz (500 kHz) on your application, also for multiple output voltages
- * construction for safety electrical disconnection satisfying EN 61558-2-17 (VDE 0570 part 2-17) respectively EN 60950 respectively EN 60065 or IEC 601
- * optional: UL-insulating system class B for impregnated transformer
- * ferrite components N 27, N 67, N 87 or N 97
- * also until ta 105°C and class F (155°C) as special version possible
- * possible winding technique: copper wire and/or HF stranded wire in class F (155°C) copper foil winding, polyimid insulated wires (3-times bandage)

type EE 42/20 potted

110 ... 650 VA

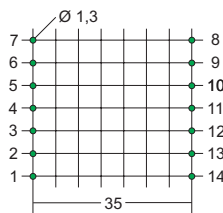
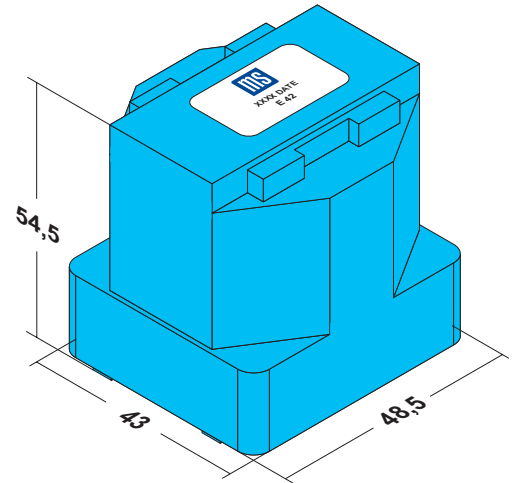
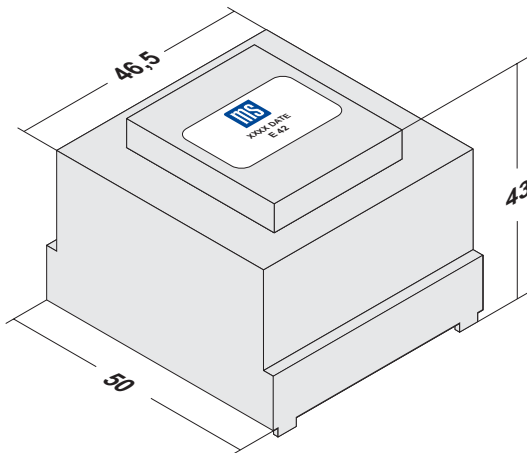

view on pin side
pin grid = 5 mm

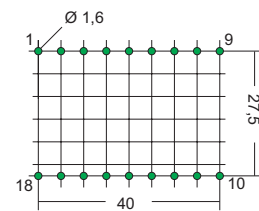

view on pin side
pin grid = 5 mm

EE 42

**maximum power as flyback-, forward- or push-pull working type
guide number on practical experience and computer based model calculations
power table is for ta 40°C / B, impregnated with N27 / N67 (standard)**

frequency	flyback	forward	push-pull
25 kHz	110 VA	140 VA	275 VA
50 kHz	220 VA	270 VA	460 VA
100 kHz	350 VA	400 VA	650 VA

- * application as SMPS, potted
- * application also as storage choke
- * custom-built development for switching frequencies from 20 kHz - 300 kHz (500 kHz) on your application, also for multiple output voltages
- * construction for safety electrical disconnection satisfying EN 61558-2-17 (VDE 0570 part 2-17) respectively EN 60950 respectively EN 60065 or IEC 601
- * optional: UL-insulating system class B for potted transformer
- * ferrite components N 27, N 67, N 87 or N 97
- * also until ta 105°C and class F (155°C) as special version possible
- * possible winding technique: copper wire and/or HF stranded wire in class F (155°C) copper foil winding, polyimid insulated wires (3-times bandage)

type EE 55/21 impregnated

180 ... 1000 VA

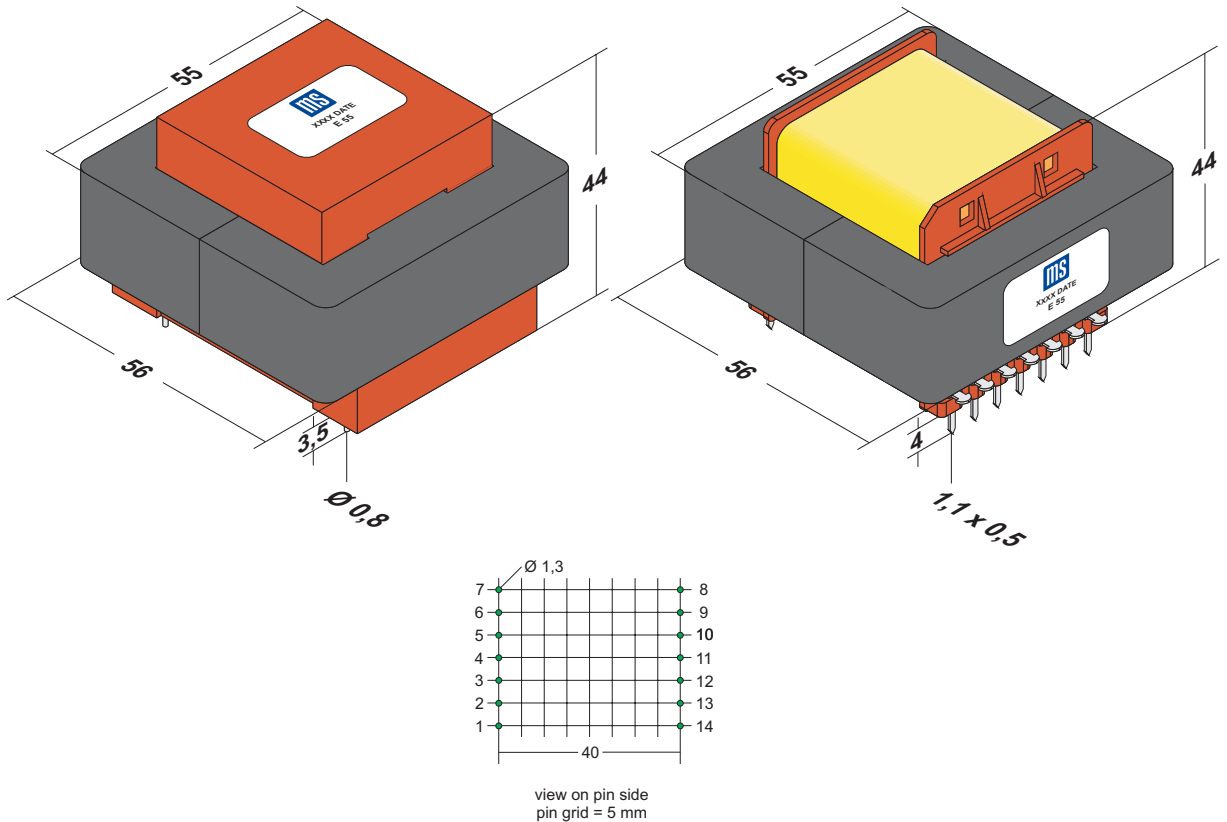

EE 55	maximum power as flyback-, forward- or push-pull working type guide number on practical experience and computer based model calculations power table is for ta 40°C / B, impregnated with N27 / N67 (standard)			
	frequency	flyback	forward	push-pull
	25 kHz	180 VA	230 VA	460 VA
	50 kHz	360 VA	440 VA	770 VA
100 kHz	-	680 VA	1000 VA	

- * application as SMPS, open or impregnated
- * application also as storage choke
- * custom-built development for switching frequencies from 20 kHz - 300 kHz (500 kHz) on your application, also for multiple output voltages
- * construction for safety electrical disconnection satisfying EN 61558-2-17 (VDE 0570 part 2-17) respectively EN 60950 respectively EN 60065 or IEC 601
- * optional: UL-insulating system class B for impregnated transformer
- * ferrite components N 27, N 67, N 87 or N 97
- * also until ta 105°C and class F (155°C) as special version possible
- * possible winding technique: copper wire and/or HF stranded wire in class F (155°C) copper foil winding, polyimid insulated wires (3-times bandage)

type EE 55/21

180 ... 1000 VA



standing impregnated

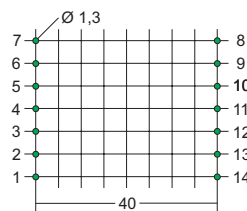
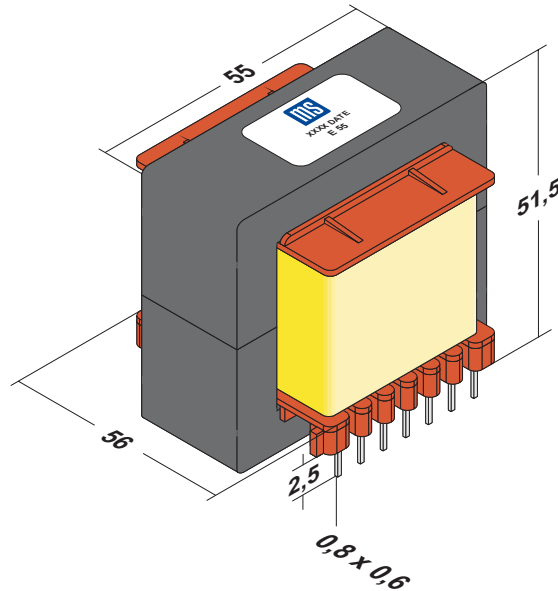

view on pin side
pin grid = 5 mm

EE 55

maximum power as flyback-, forward- or push-pull working type
guide number on practical experience and computer based model calculations
power table is for t_a 40°C / B, impregnated with N27 / N67 (standard)

frequency	flyback	forward	push-pull
25 kHz	180 VA	230 VA	460 VA
50 kHz	360 VA	440 VA	770 VA
100 kHz	-	680 VA	1000 VA

- * application as SMPS, open or impregnated
- * application also as storage choke
- * custom-built development for switching frequencies from 20 kHz - 300 kHz (500 kHz) on your application, also for multiple output voltages
- * construction for safety electrical disconnection satisfying EN 61558-2-17 (VDE 0570 part 2-17) respectively EN 60950 respectively EN 60065 or IEC 601
- * optional: UL-insulating system class B for impregnated transformer
- * ferrite components N 27, N 67, N 87 or N 97
- * also until t_a 105°C and class F (155°C) as special version possible
- * possible winding technique: copper wire and/or HF stranded wire in class F (155°C) copper foil winding, polyimid insulated wires (3-times bandage)

type EE 55/21 potted

200 ... 1100 VA

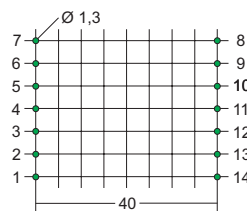
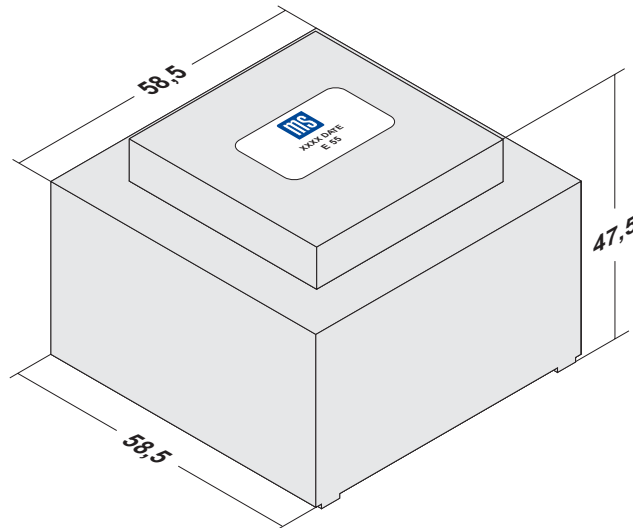

view on pin side
pin grid = 5 mm

EE 55	maximum power as flyback-, forward- or push-pull working type guide number on practical experience and computer based model calculations power table is for ta 40°C / B, impregnated with N27 / N67 (standard)			
	frequency	flyback	forward	push-pull
	25 kHz	200 VA	250 VA	500 VA
	50 kHz	400 VA	480 VA	850 VA
	100 kHz	-	750 VA	1100 VA

- * application as SMPS, potted
- * application also as storage choke
- * custom-built development for switching frequencies from 20 kHz - 300 kHz (500 kHz) on your application, also for multiple output voltages
- * construction for safety electrical disconnection satisfying EN 61558-2-17 (VDE 0570 part 2-17) respectively EN 60950 respectively EN 60065 or IEC 601
- * optional: UL-insulating system class B for potted transformer
- * ferrite components N 27, N 67, N 87 or N 97
- * also until ta 105°C and class F (155°C) as special version possible
- * possible winding technique: copper wire and/or HF stranded wire in class F (155°C) copper foil winding, polyimid insulated wires (3-times bandage)