

radio interference-chokes current-compensation

E 30/7-30

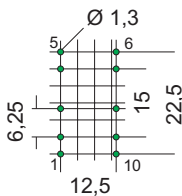

view on pin side
pin grid = 3,75 mm

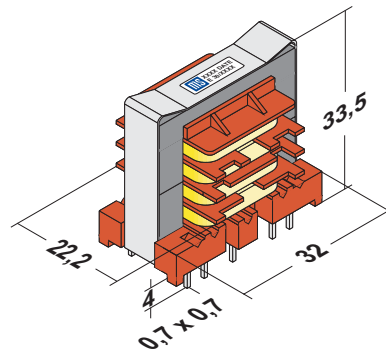
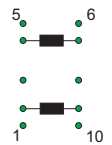

winding schematic

E 30/7-30	type	rated current	inductance +30%/-20% [mH]	stray inductance typ [μ H]	winding resistance for each winding [mOhm] (typ)
	MS 2610	0,5 A	2 x 150	2000	3200
MS 2611	1,0 A	2 x 60	900	1000	
MS 2612	1,4 A	2 x 30	450	500	
MS 2613	2,0 A	2 x 12	150	200	
MS 2614	3,0 A	2 x 6,5	80	100	
MS 2615	4,0 A	2 x 4,5	50	65	

- * core with very high permeability
- * special version with other pinning on demand

technical datas:

rated voltage:	250 VAC / 50/60 Hz
rated current:	0,5 ... 4,0 A
test voltage winding/winding	1500 VAC / 50 Hz 2 sec
test-voltage winding 1+2/core:	1500 VAC / 50 Hz 2 sec
bobbin:	4-chamber ultramide A3X2G5 UL 94-V0
impregnate:	E 8571 UL-listed

radio interference-chokes current-compensation

E 30/7-35

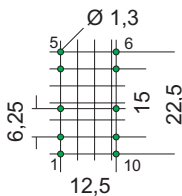
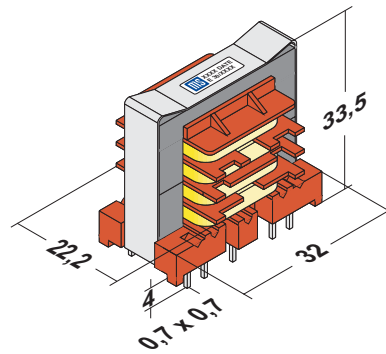

view on pin side
pin grid = 3,75 mm

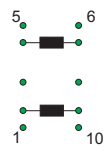

winding schematic

E 30/7-30	type	rated current	inductance +30%/-20% [mH]	stray inductance typ [µH]	winding resistance for each winding [mOhm] (typ)
	MS 2620	0,5 A	2 x 200	2000	3200
MS 2621	1,0 A	2 x 80	900	1000	
MS 2622	1,4 A	2 x 40	450	500	
MS 2623	2,0 A	2 x 16	150	200	
MS 2624	3,0 A	2 x 9	80	100	
MS 2625	4,0 A	2 x 6,5	50	65	

- * core with very high permeability
- * special version with other pinning on demand

technical datas:

rated voltage:	250 VAC / 50/60 Hz
rated current:	0,5 ... 4,0 A
test voltage winding/winding	1500 VAC / 50 Hz 2 sec
test-voltage winding 1+2/core:	1500 VAC / 50 Hz 2 sec
bobbin:	4-chamber ultramide A3X2G5 UL 94-V0
impregnate:	E 8571 UL-listed